

# Model: VILIČAR

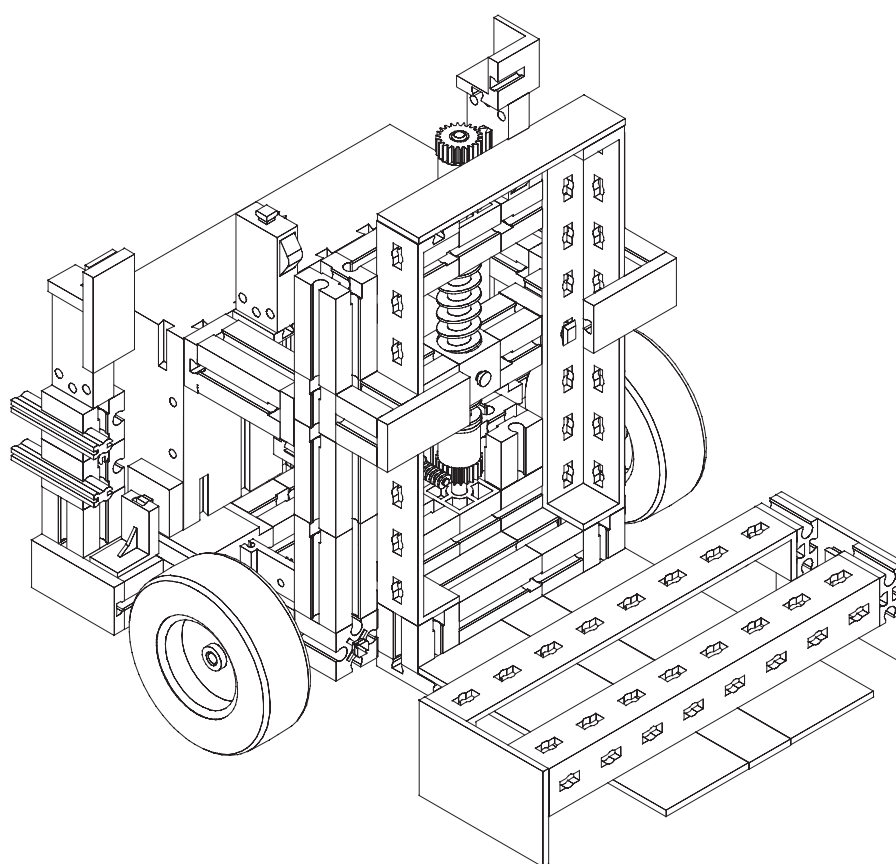

# Model: VILIČAR - SASTAVNICA

1		30263	5		32330	4		37783
1		31036	2		32850	1		37858
2		31060	18		32879	1		37925
6		31061	24		32881	1		37926
2		31063	13		32882	1		38240
2		31078	2		32883	1		38244
1		31124	2		32913	1		38245
15		31336	2		35033	2		38248
15		31337	1		35113	2		38251
1		31360	1		35969	5		38423
1		31690	4		36294	3		38428
2		31915	1		36573			
2		31982	2		37237			
2		32064	4		37238			
1		32085	3		37468			
3		32293	2		37679			
1		32321						

# Model: VILIČAR

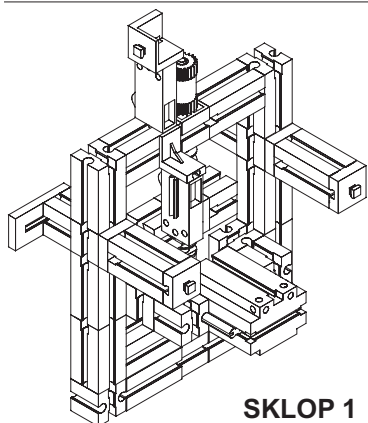

SKLOP 1

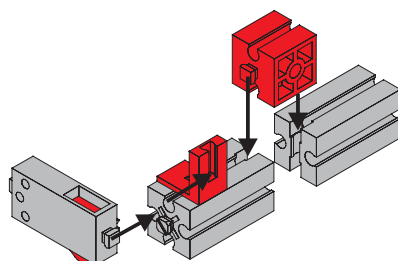
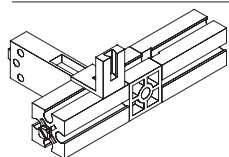

1

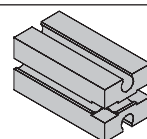

x 2 - 32879

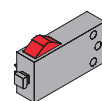

x 1 - 37783



x 1 - 38423

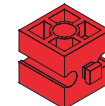

x 1 - 32064

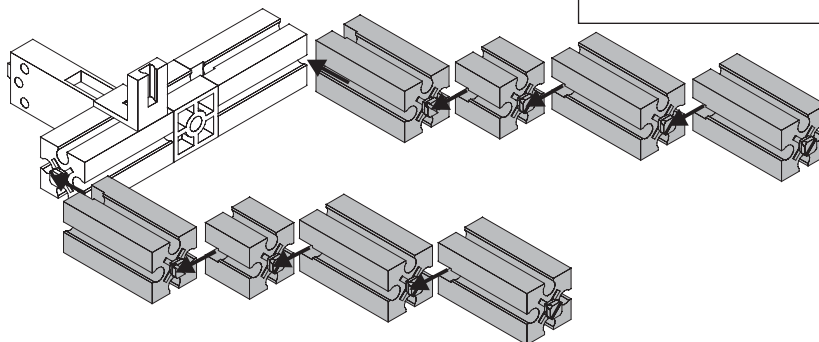
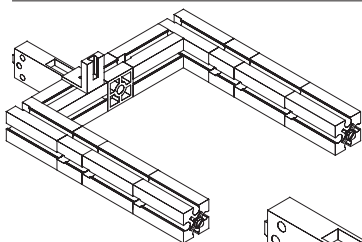

2

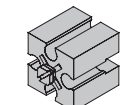

x 2 - 32881

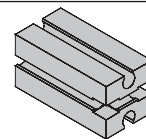

x 6 - 32879

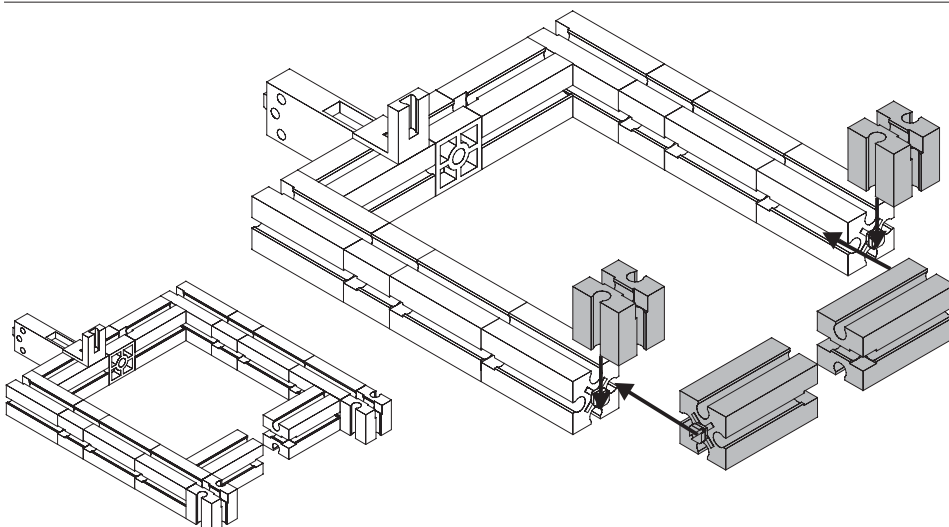

3

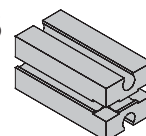

x 2 - 32879

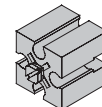

x 2 - 32881

# Model: VILIČAR

2

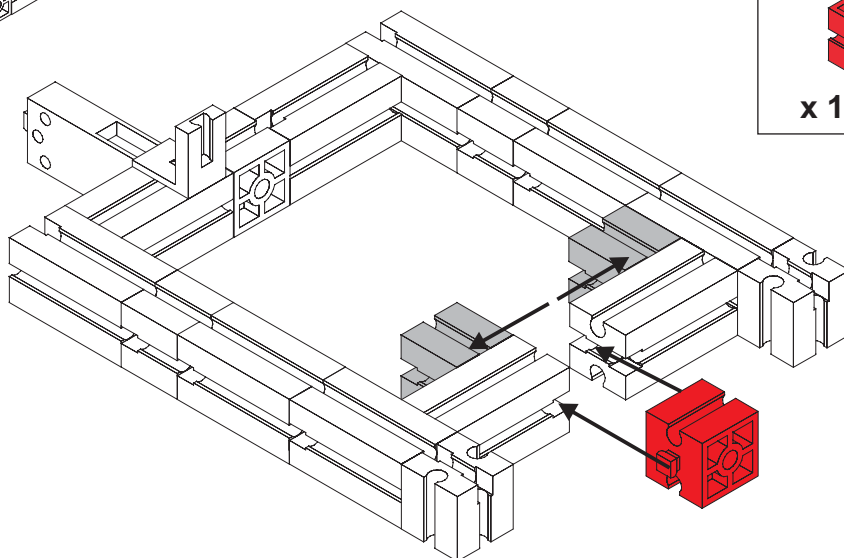
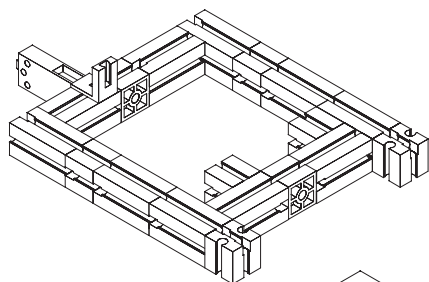

4

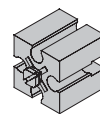

x 2 - 32881

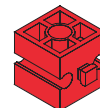

x 1 - 32064

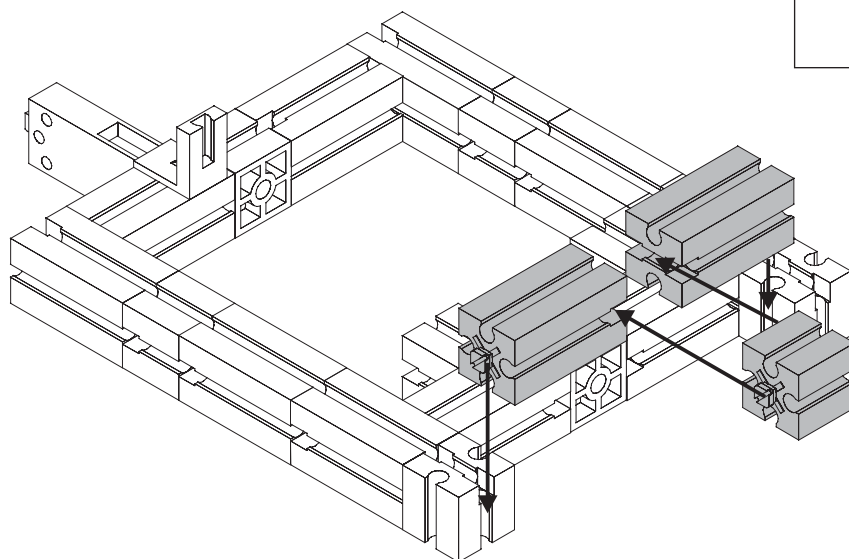
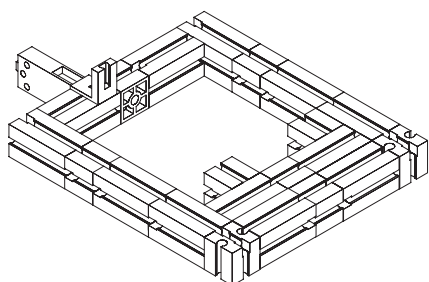

5

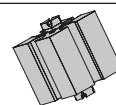

x 1 - 32882

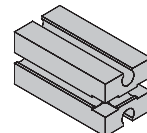

x 2 - 32879





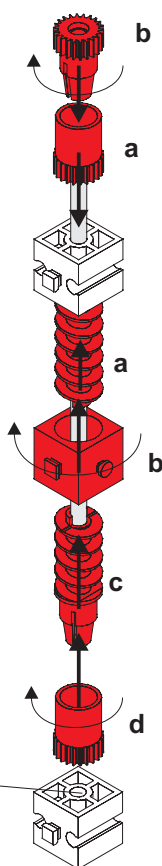
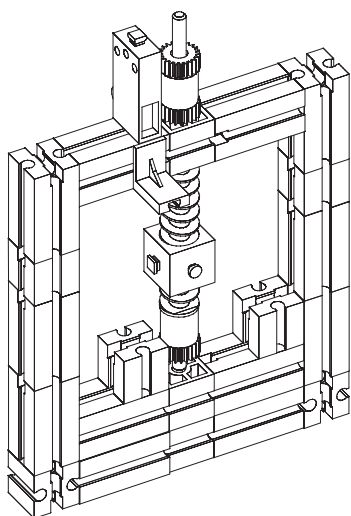

# Model: VILIČAR

3

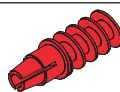

vrh osovine treba utaknuti u drugu rupu

6

-  x 1 - 37858
-  x 1 - 37926
-  x 1 - 37925
-  x 1 - 35113
-  x 2 - 31915
-  x 1 - 31036

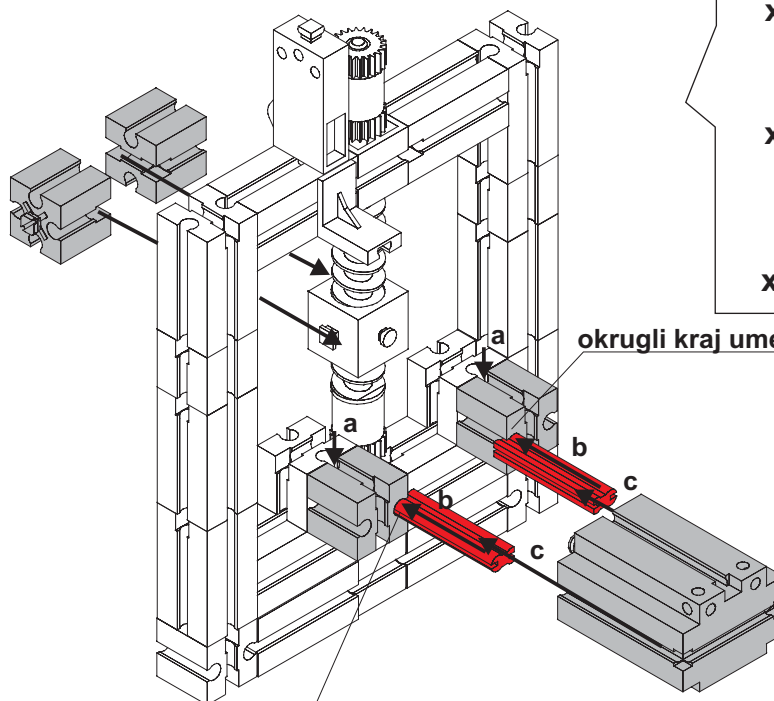
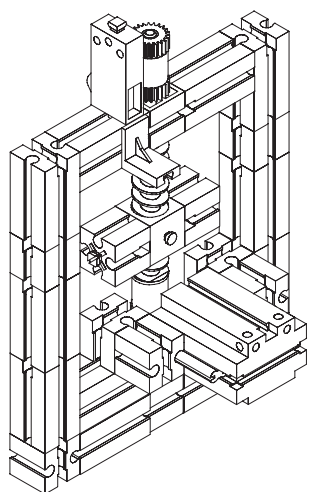

7

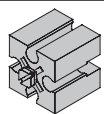
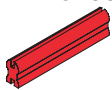
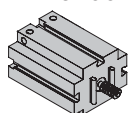
-  x 4 - 32881
-  x 2 - 31061
-  x 1 - 32293

okrugli kraj umetnuti u utor

okrugli kraj umetnuti u utor

# Model: VILIČAR

4

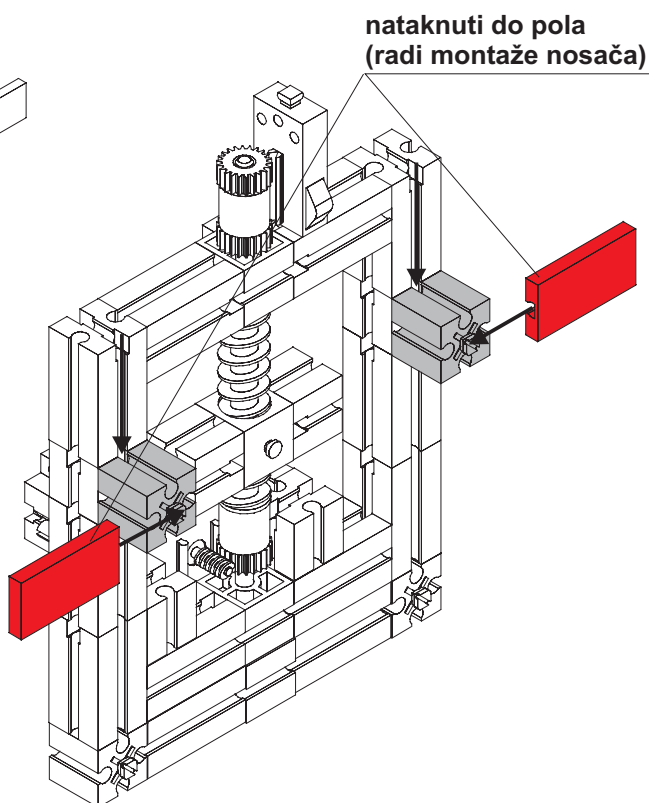
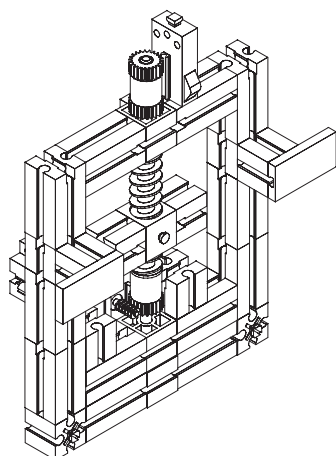

8

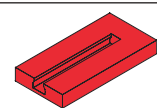

x 2 - 32330

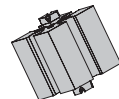

x 2 - 32882

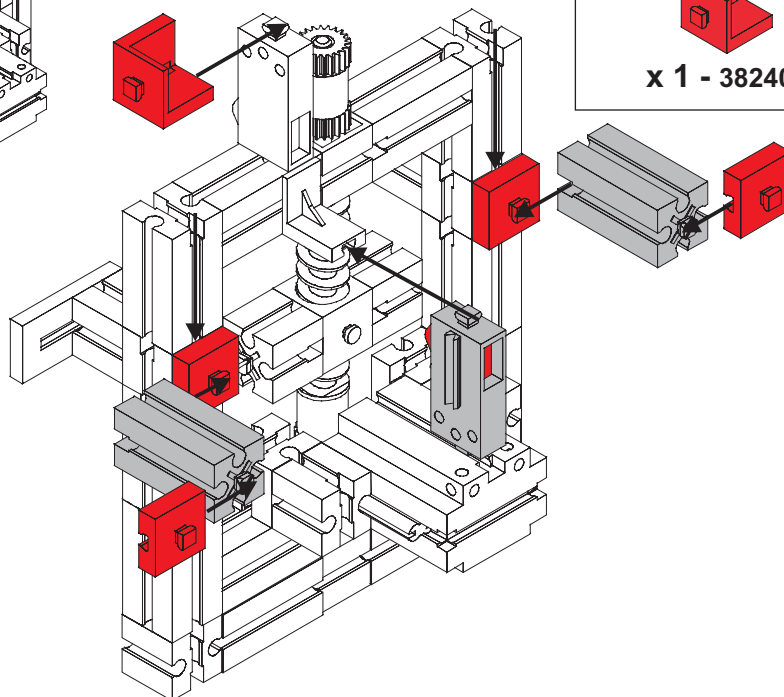
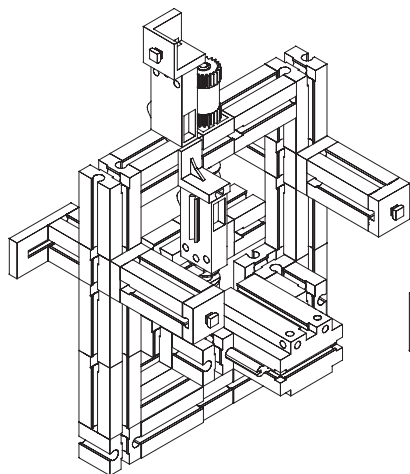

9

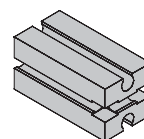

x 2 - 32879



x 1 - 38240



x 2 - 37238



x 2 - 37237



x 1 - 37783

# Model: VILIČAR

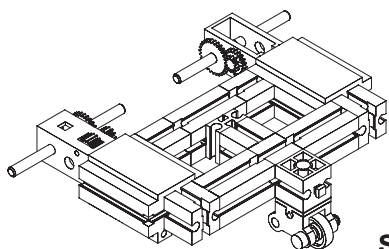

SKLOP 2

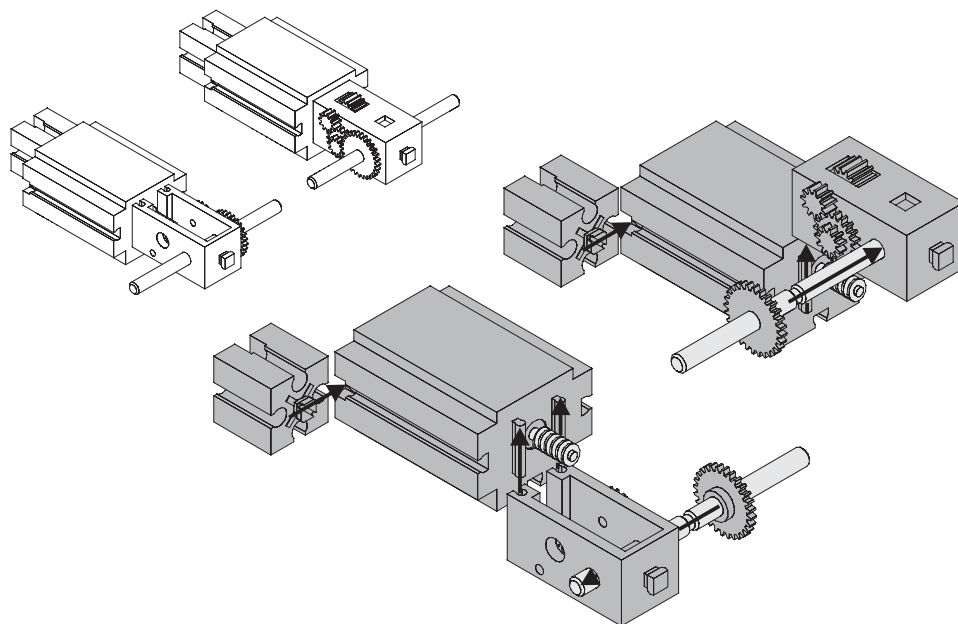

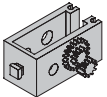
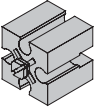
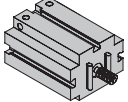
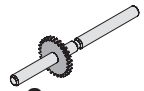

10

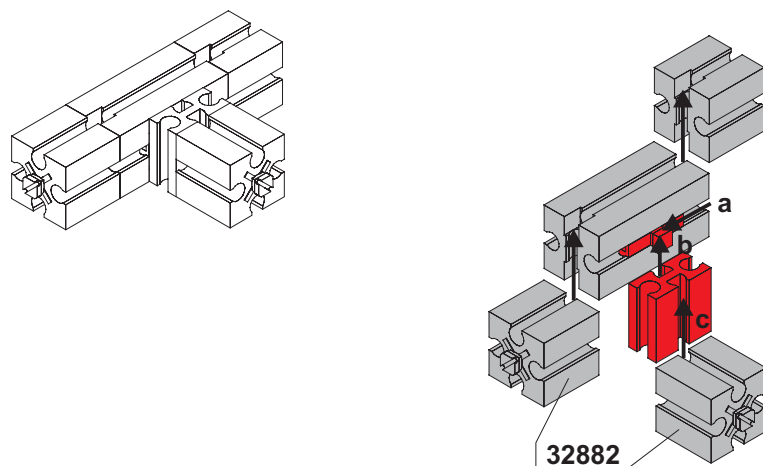
-  x 2 - 31078
-  x 2 - 32881
-  x 2 - 32293
-  x 2 - 31063

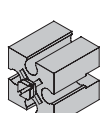
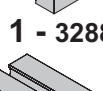

11

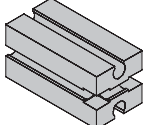
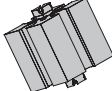
-  x 1 - 31982
-  x 1 - 32881
-  x 1 - 37468
-  x 1 - 32879
-  x 2 - 32882

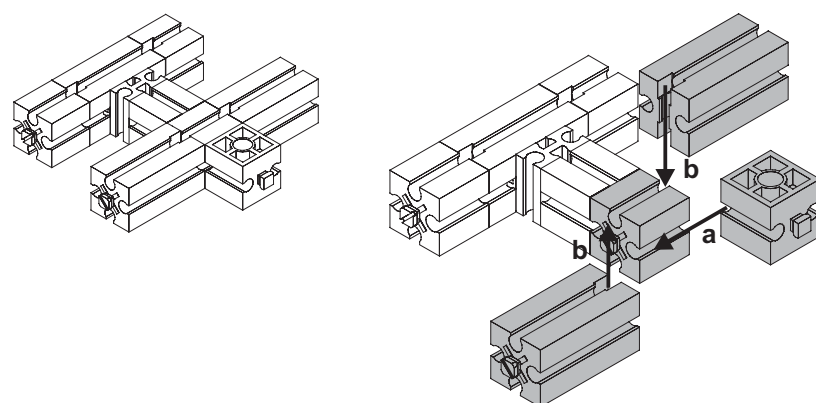

12

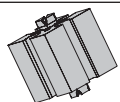
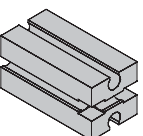
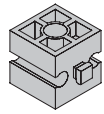

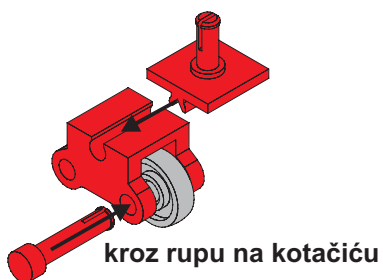
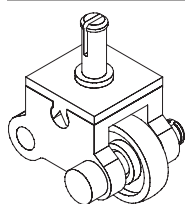

-  x 1 - 32882
-  x 2 - 32879
-  x 1 - 32321

# Model: VILIČAR

6

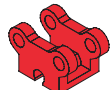

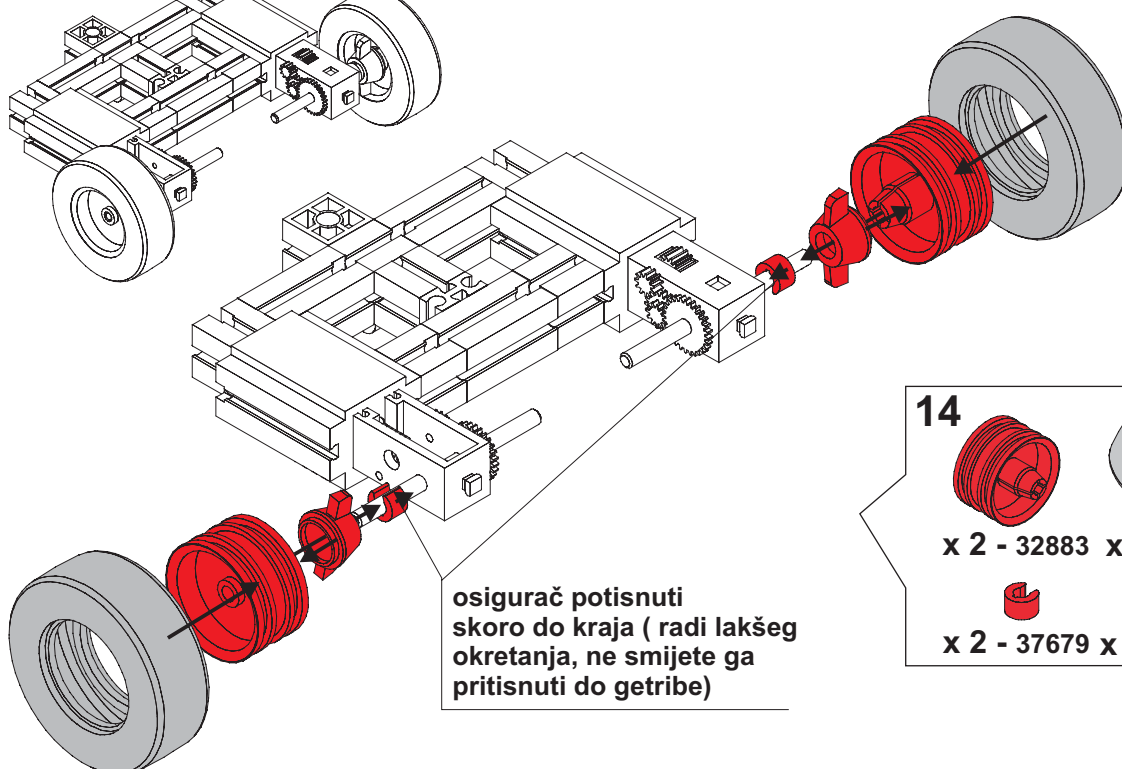
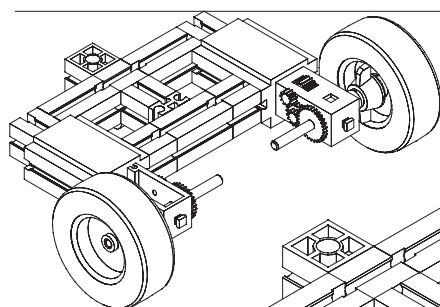
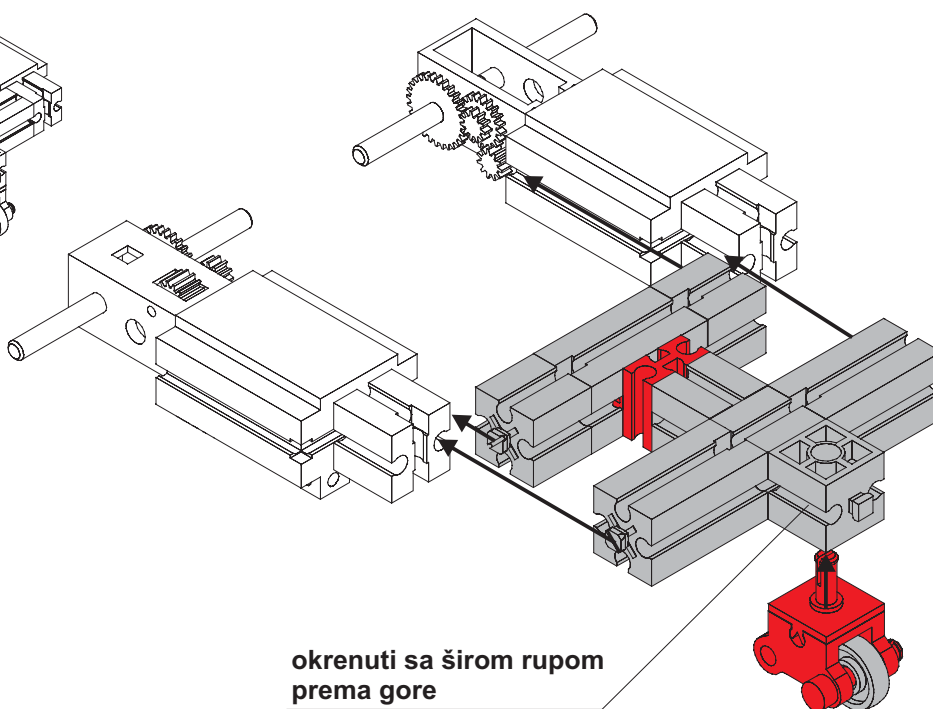
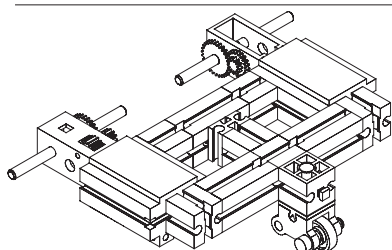

13

-  x 1 - 32085
-  x 1 - 36573
-  x 1 - 31124
-  x 1 - 31690

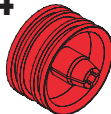
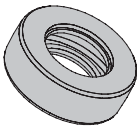

14

-  x 2 - 32883
-  x 2 - 32913
-  x 2 - 37679
-  x 2 - 35033



# Model: VILIČAR

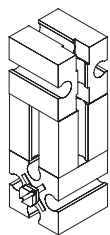

2 x SKLOP

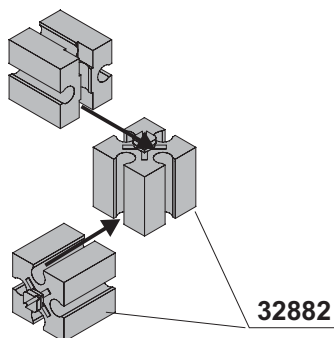

15

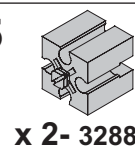

x 2- 32881

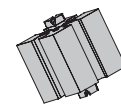

x 4- 32882

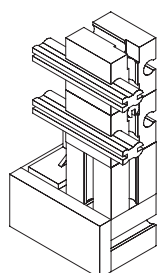

Lijevi

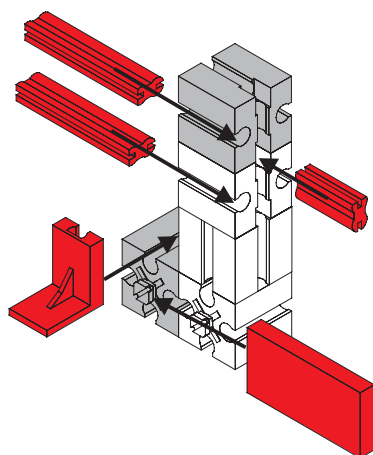

16

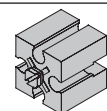

x 2- 32881

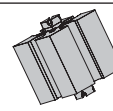

x 2- 32882

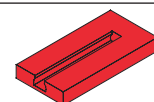

x 2 - 32330

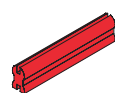

x 4- 31061



x 2 - 38423

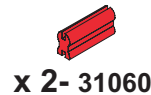

x 2- 31060

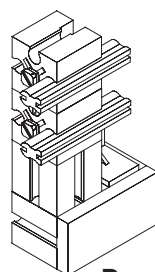

Desni

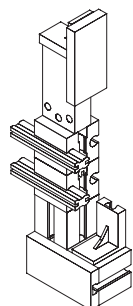
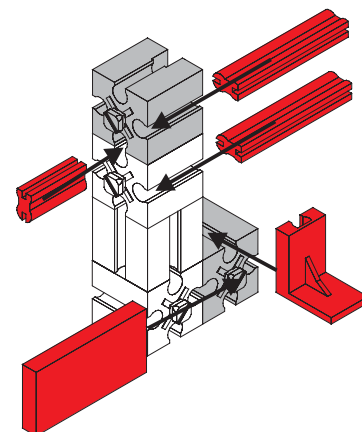

Desni

17

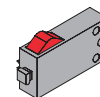

x 1 - 37783

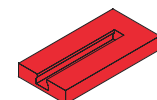

x 1 - 32330



x 1 - 38423

# Model: VILIČAR

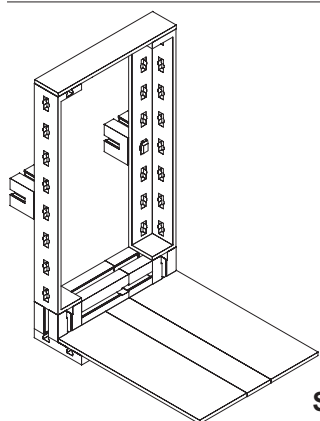

SKLOP 3

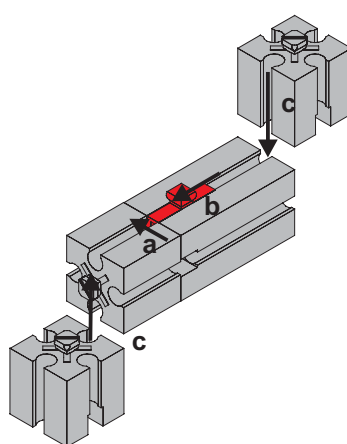
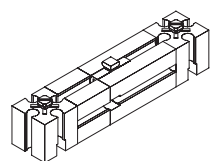

18

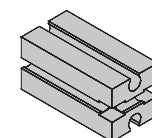

x 1 - 32879

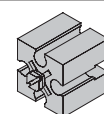

x 2 - 32881

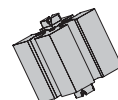

x 1 - 32882



x 1 - 31982

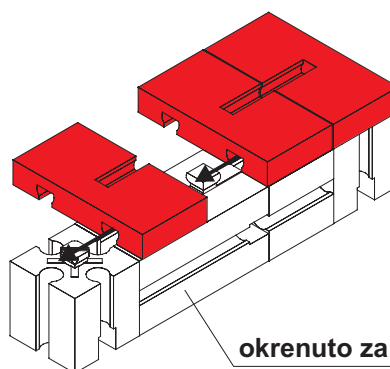
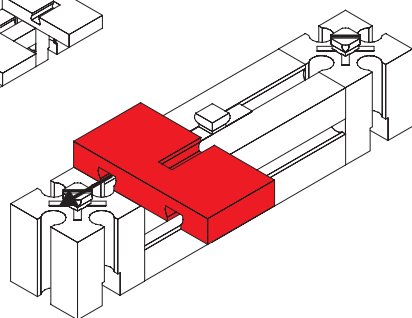
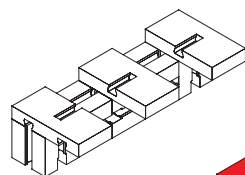

okrenuto za 180°

19

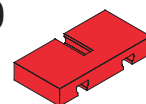

x 3 - 38428

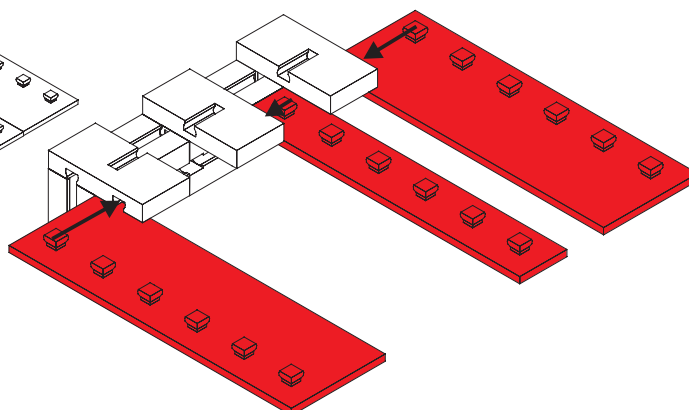
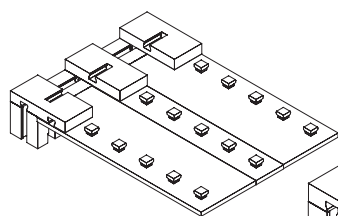

20

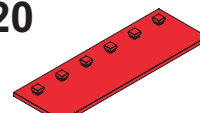

x 2 - 38251

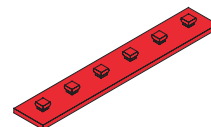

x 1 - 38245

# Model: VILIČAR

9

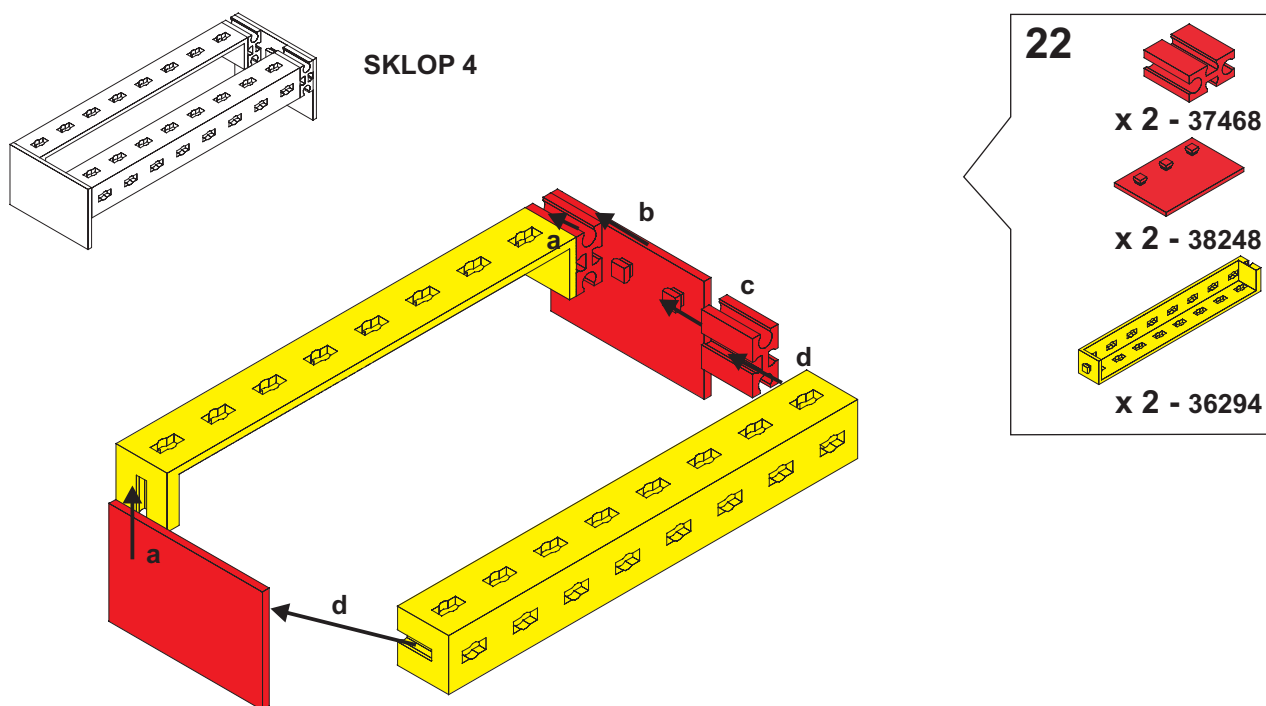
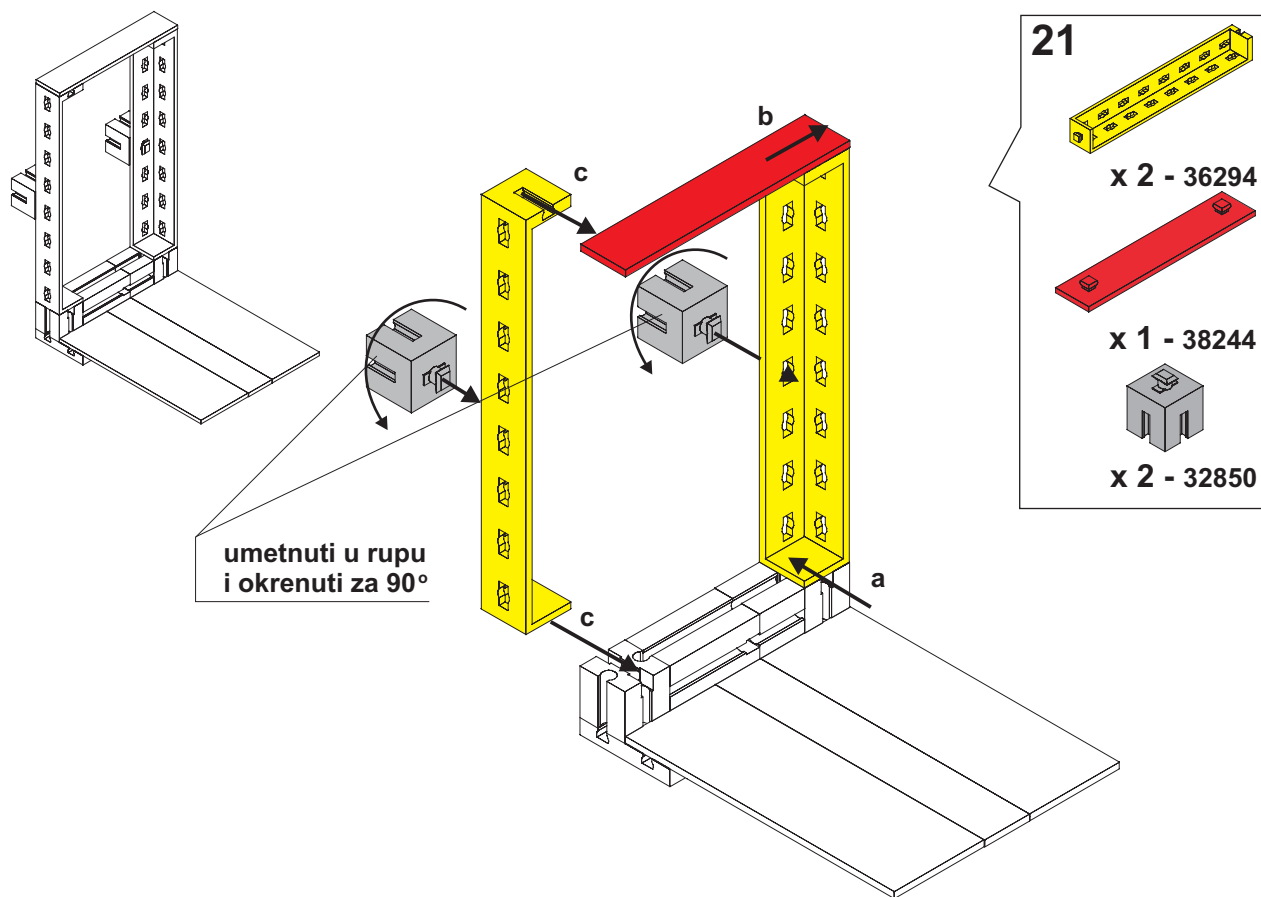

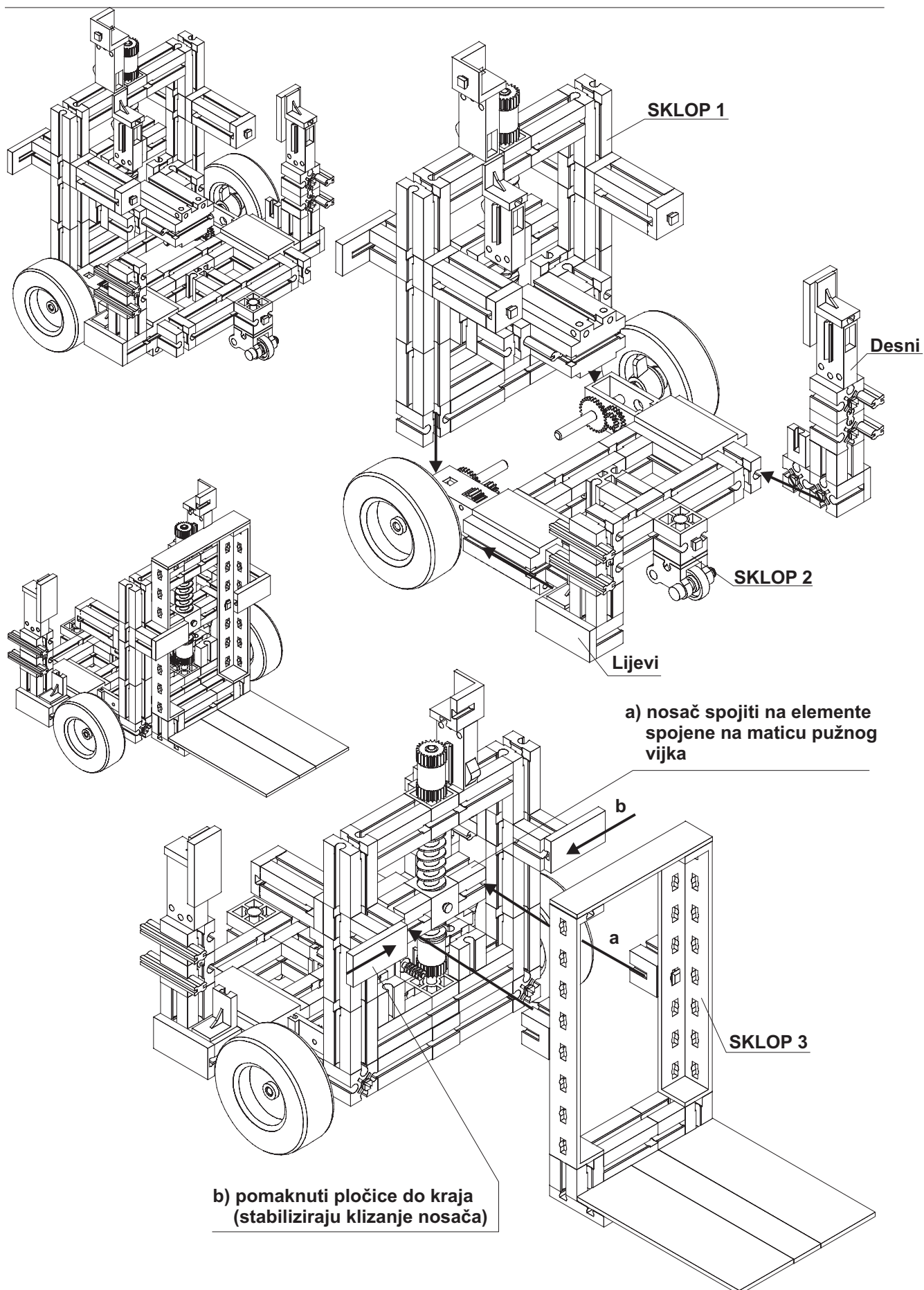

# Model: VILIČAR

11

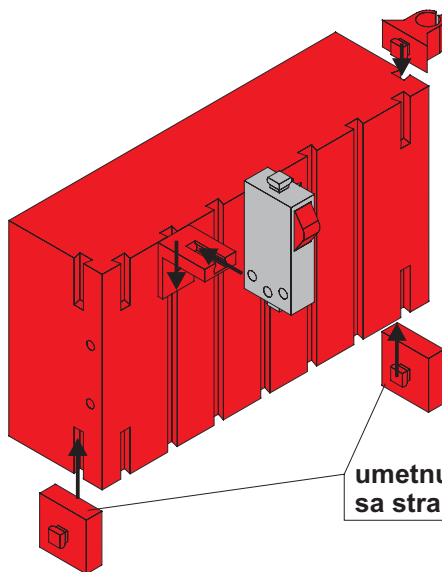
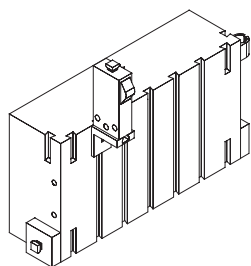

23

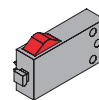

x 1 - 37783

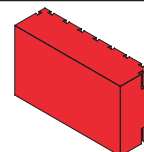

x 1 - 30263



x 1 - 35969



x 1 - 38423



x 2 - 37238

umetnuti u žlijeb  
sa strane

b) spustiti nosače u utore  
na kutiji za baterije

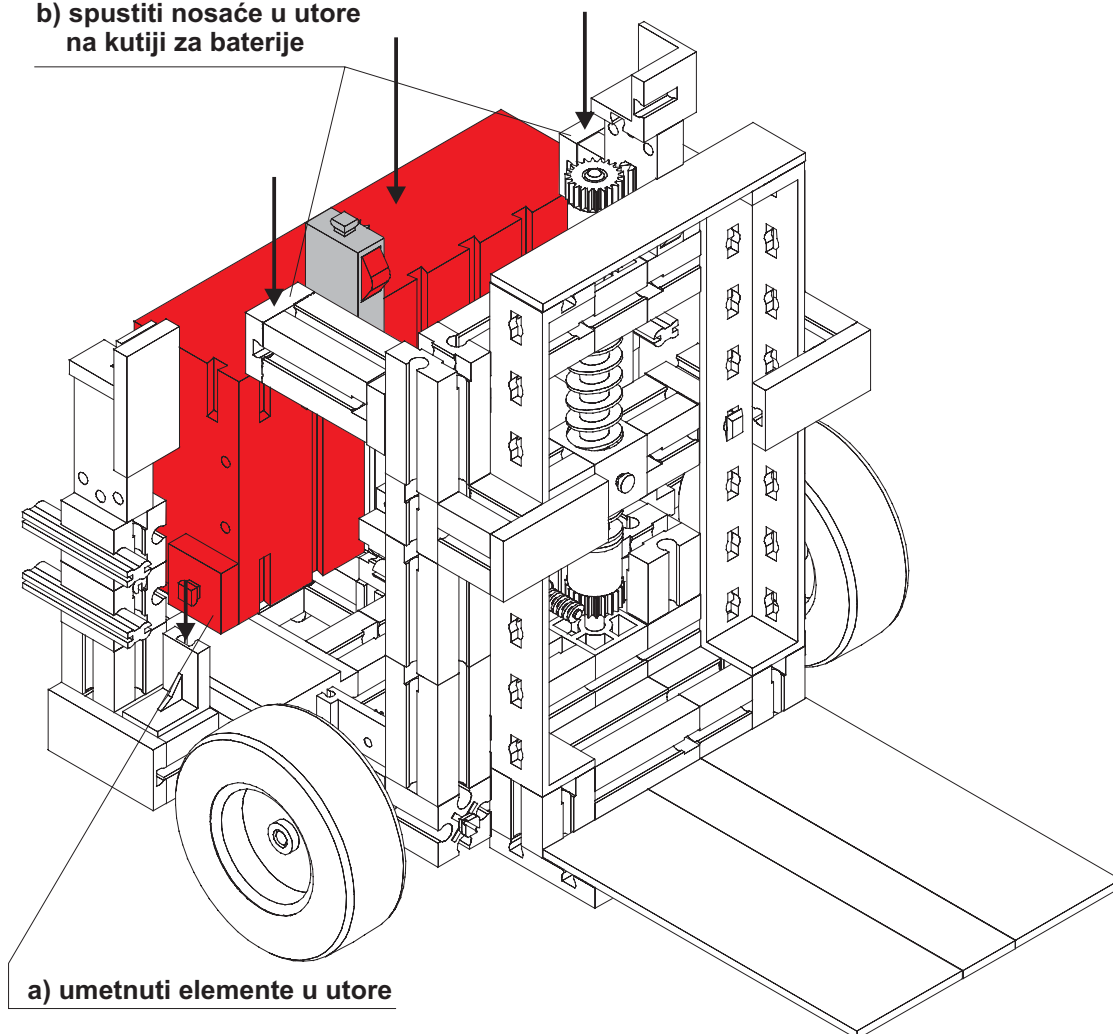

a) umetnuti elemente u utore

# Model: VILIČAR ULAZNI I IZLAZNI UREĐAJI 12

**tipkalo 1**  
glavni prekidač  
napajanja, ako se  
koristi sučelje  
FISCHER

**tipkalo 4**  
RESET taster za  
sučelje FISCHER

pogled od naprijed

priključak napajanja  
za sučelje FISCHER

**tipkalo 2**  
senzor za dolje

pogled od pozadi na  
noseći dio viličara

**tipkalo 3**  
senzor za gore

**motor 2**  
u oba smijera

**motor 3**  
u oba smijera

**motor 1**  
u oba smijera

pogled od pozadi na  
pogonski dio viličara

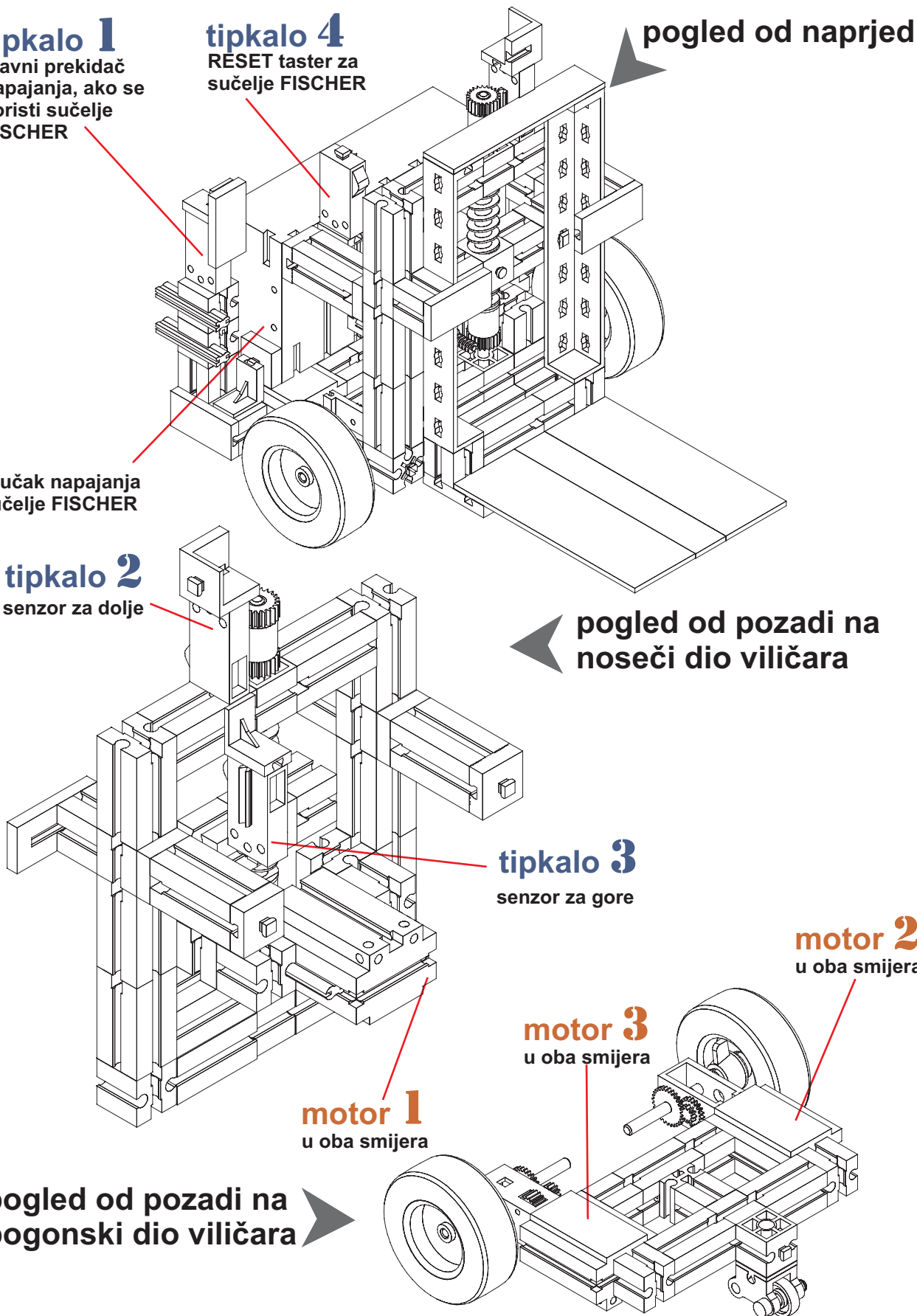

## spajanje na sučelje - PARALELNO ULAZNO IZLAZNO

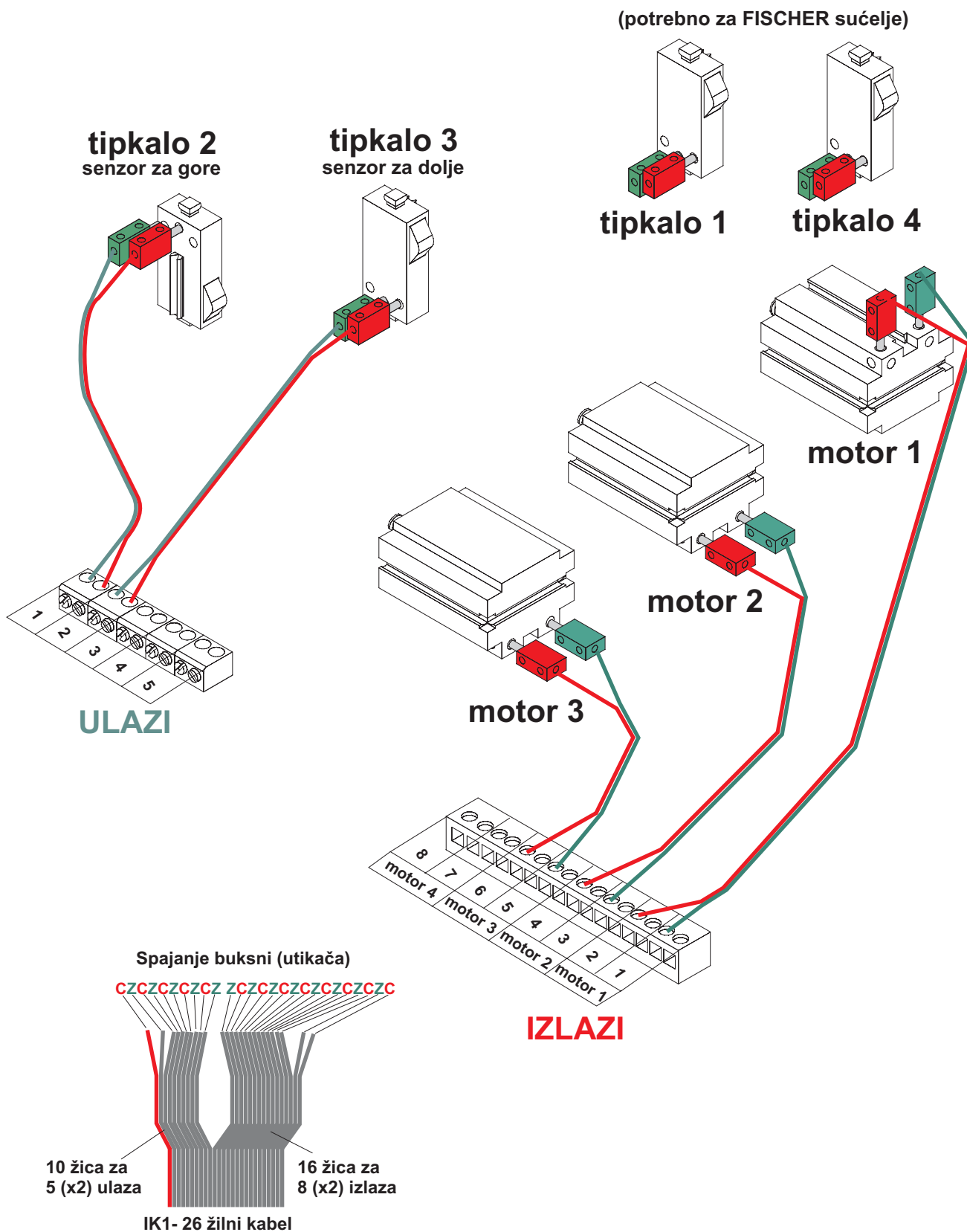

Priključni uređaji sa rednim brojevima prikazani su na strani 12.